

RJA/B-30/30H

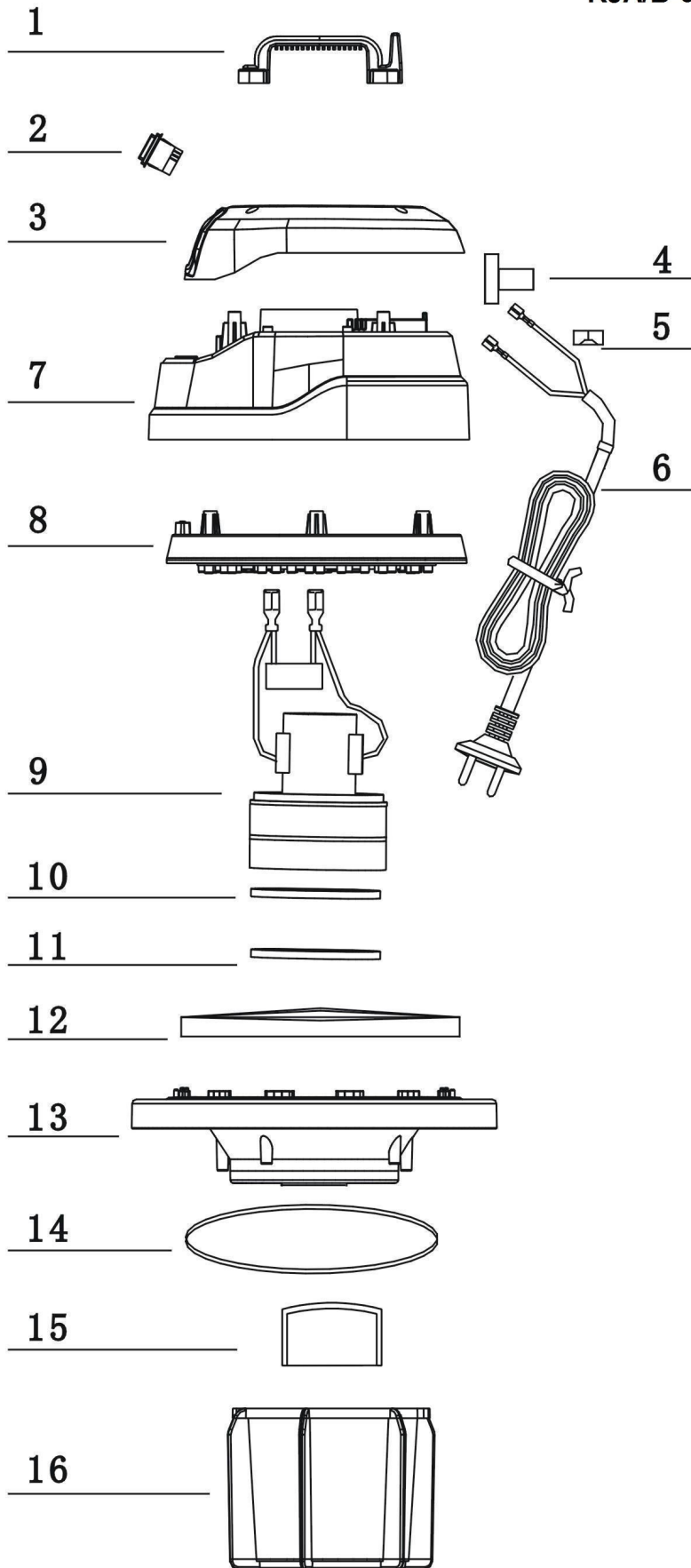

1	Lift handle
2	Water-proof switch
3	Top cover
4	Cable sleeve
5	Cable clip
6	Power cable
7	Round frame
8	Motor cover
9	Model-A motor
10	Rubber ring for motor
11	Rubber rug for motor
12	Spong for eliminate noise
13	Motor base
14	Rubber ring for motor base
15	Float
16	Float basket

RJA/B-30/30H

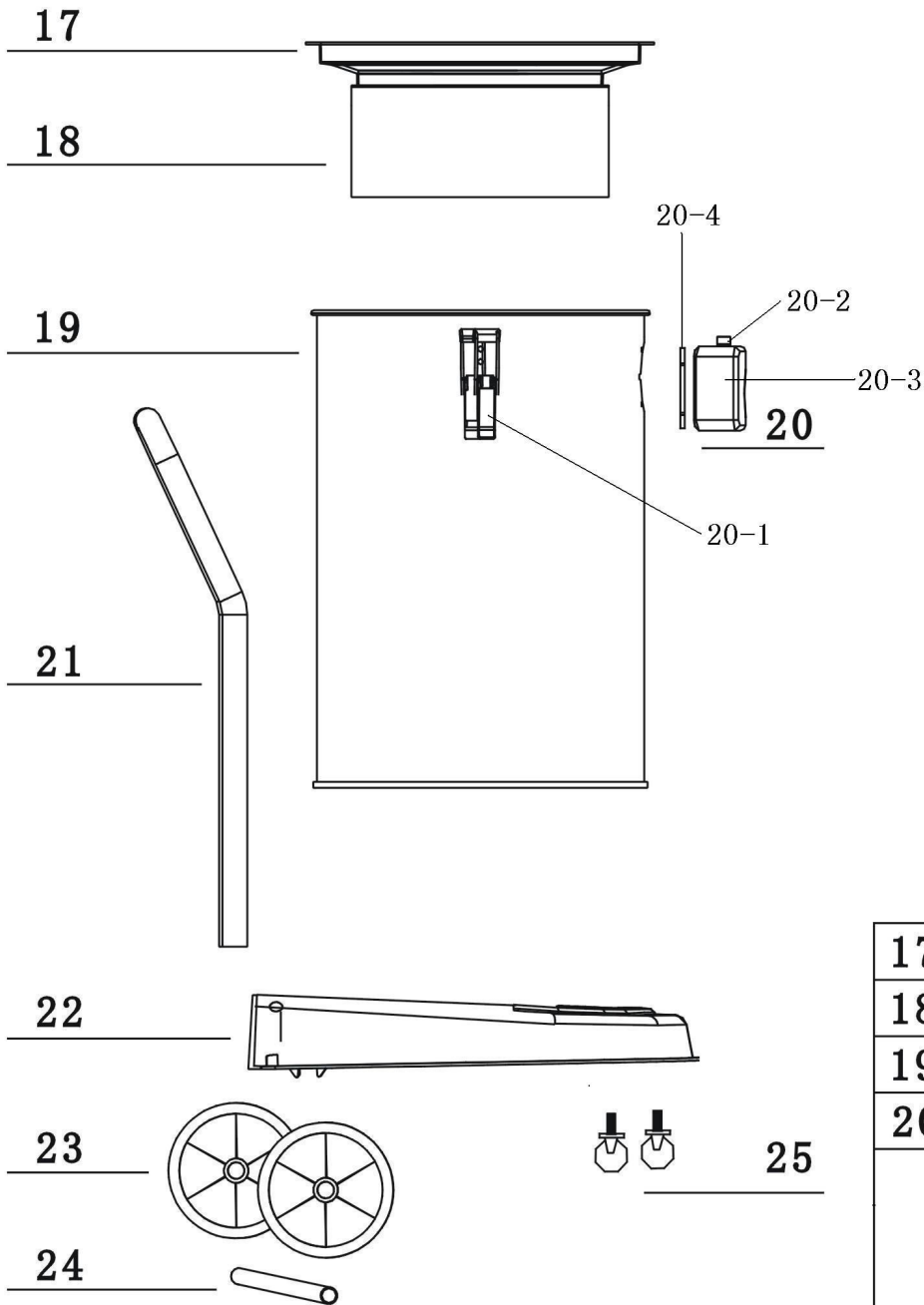

<b>17</b>	Dustbag shelve
<b>18</b>	Dust bag
<b>19</b>	Stainless steel tank
<b>20</b>	Suction inlet base parts
	20-1:Locking block
	20-2:Spring
	20-3:Suction inlet base
	20-4:Pad ring
<b>21</b>	Iron handel
<b>22</b>	Base
<b>23</b>	Big wheel
<b>24</b>	Iron alex of big wheel
<b>25</b>	Castor

RJA/B-30/30H

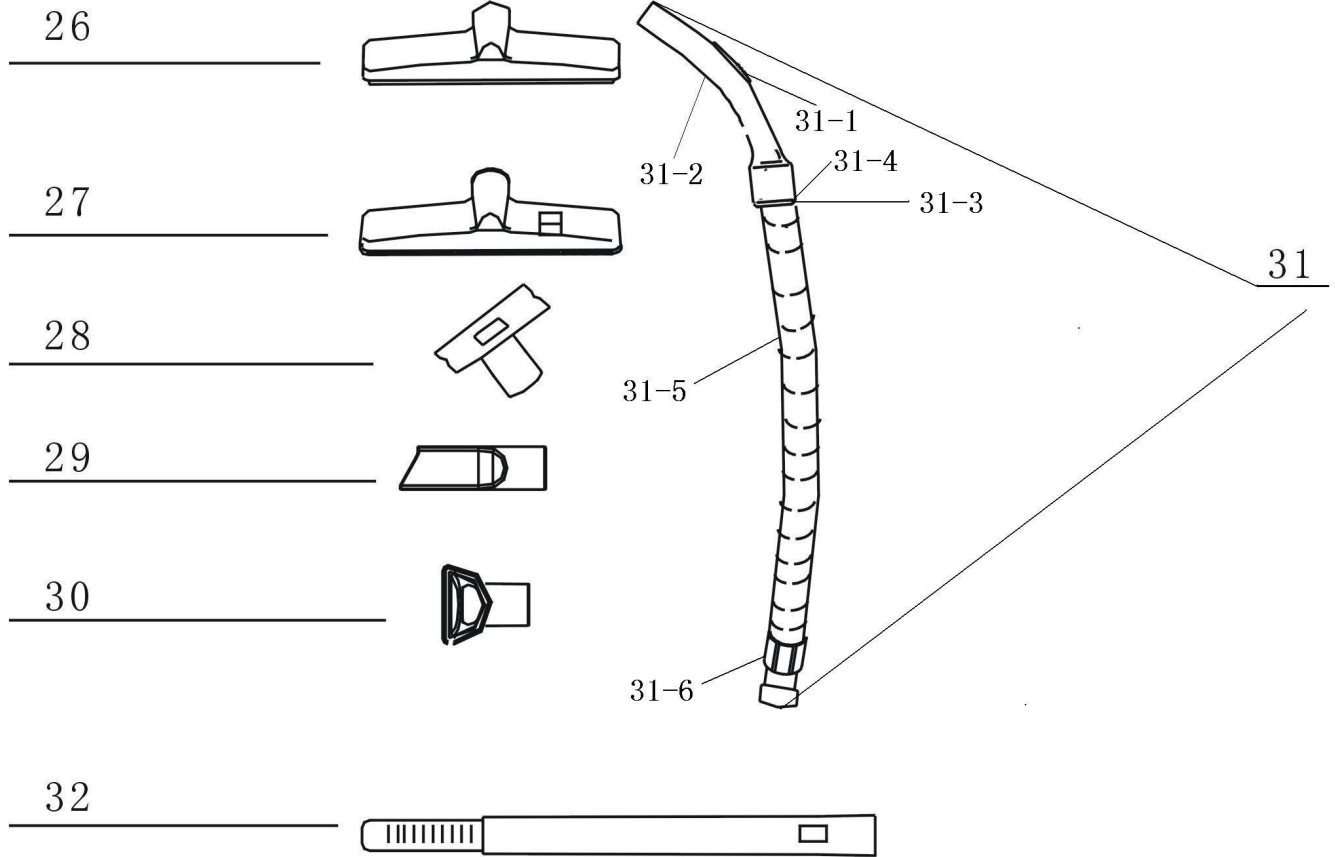

26	Wet floor nozzle
27	Dry floor nozzle
28	Sofa floor nozzle
29	Crevice nozzle
30	Dust brush
31	Suction hose parts
	31-1:Air volume adjustment block
	31-2:Long connector
	31-3:Long connector threaded ring
	31-4:Locking ring
	31-5:Suction hose
	31-6:Short connector
32	Metal tube